

Name	Easel	A
Typology	Occasional chair	
Designer	Shane Schneck	



Description	Smallness is not always analogous to comfort – despite the seat’s reduced proportions, the angle and position make it remarkably comfortable for the curiously small footprint. When in use the seat becomes invisible support for the seated, hence the name Easel. The base is constructed with half-lap joints in solid oak and offers a stable feel despite its dimensions.
-------------	---

Name

Easel

B

Material

Stained oak

Examples



14b.1



14b.3



14b.2

Name	Easel	C
-------------	--------------	----------

Material	Stained oak	14b
-----------------	--------------------	------------

Colours	14b.1	oak natural
----------------	--------------	--------------------



14b.2	oak moyen
--------------	------------------



14b.3	oak black
--------------	------------------



Name

Easel



Dimensions

58x31x74cm

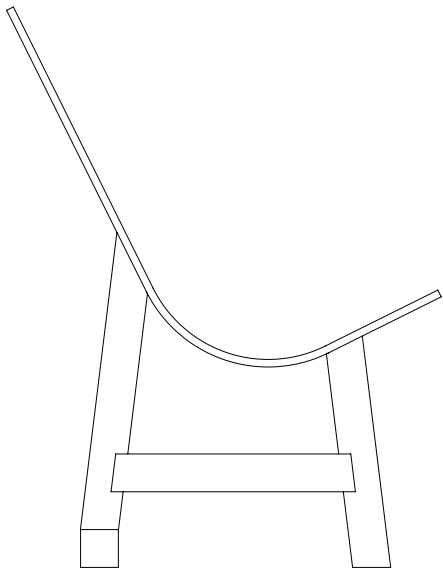
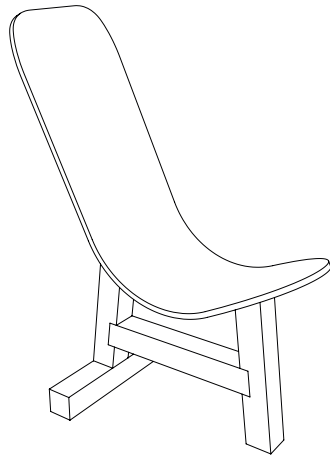
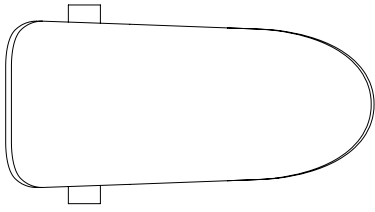

58

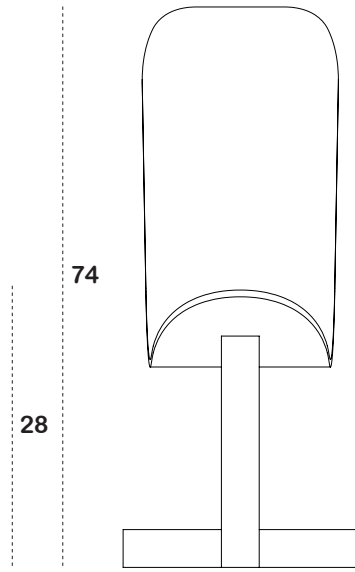

74

28

31