





**DANTE**  
GOODS *and* BADS



Name	Hold On
Typology	Hold all
Designer	Haus Otto

Dimensions 26 x 15 x 26cm

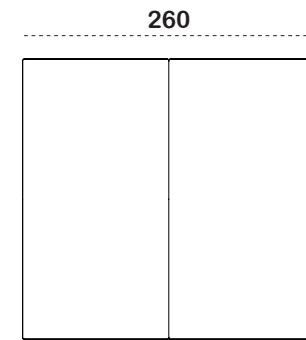
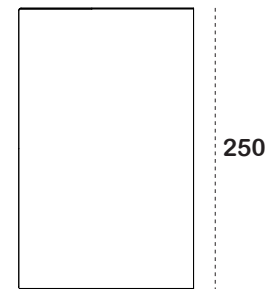
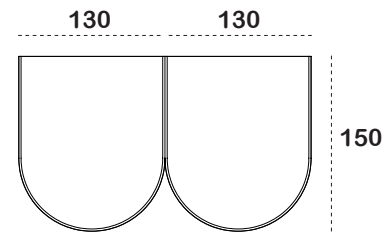
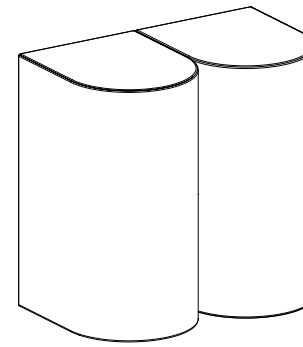

**Description** The upholstered wall hook creates a minimalist, horizontal storage platform and offers the possibility to attach your daily items to a wall using a quick, charming gesture. The hook can be vertically and horizontally attached to the wall and comes in various finishes.

Material	Velvet		
Colours	Ø1.1	creme	
	Ø1.2	sunflower	
	Ø1.3	rose	
	Ø1.4	lilac	
	Ø1.5	pistaccio	
	Ø1.6	light blue	
	Ø1.7	ocean blue	



**Velvet** Light soiling of the Hold On velvet version can usually be easily brushed out with a clothes brush. Always brush in the direction of the grain and do not press too hard. Then clean the area with a damp, unused cloth.





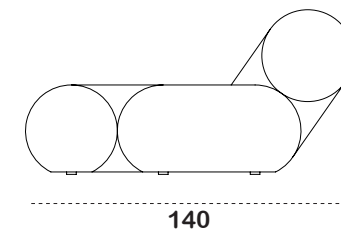
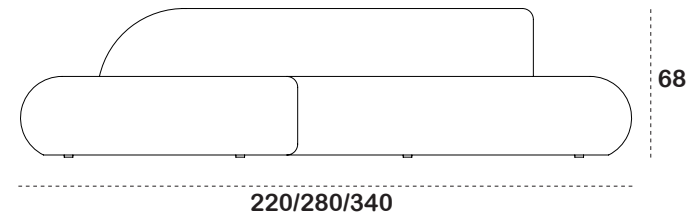
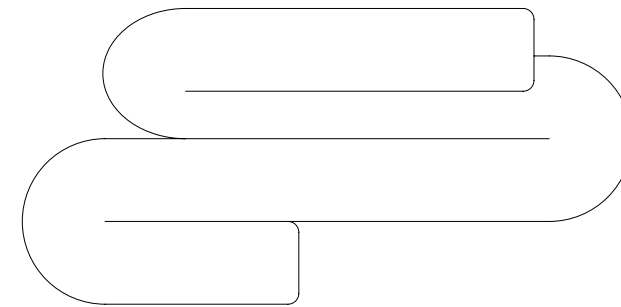
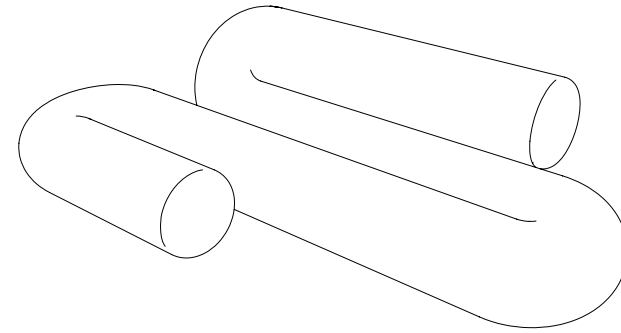

Name	Serpentine
Typology	Sofa
Designer	Christophe de la Fontaine

Dimensions 220/280/340 x 140 x 68cm

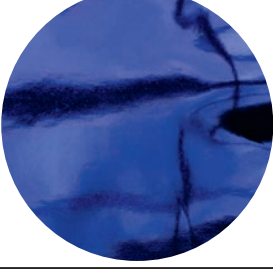

**Description** Serpentine takes the challenge of rethinking a modern sofa by incorporating different seating solutions in one fluid object. The alternation of back and leg support mimics the functionality of a classic seat, a pouf, and a chaise longue. Serpentine looks like a conclusive singular, but is actually a system, available in different sizes, constellations, and finishes. The mix of different foam densities is carefully set up to appear robust, yet soft and inviting to enjoy the luscious comfort.

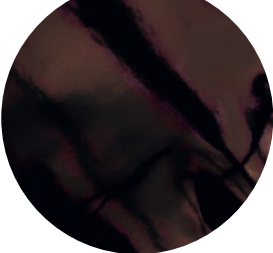
Material	Vegan leather metallic		
Colours	ø6.1	silver	
	ø6.2	rose	
	ø6.3	golden yellow	
	ø6.4	electric blue	
	ø6.5	dark green	
	ø6.5	dark copper	



**Vegan leather metallic** When it comes to caring for metallised vegan leather and keeping it from fading, protecting it from dirt and dust is a top priority. We recommend you clean your metallic Serpentine regularly with a soft damp cloth.





Name	The Third
Typology	Bar stool
Designer	Christophe de la Fontaine



Dimensions high 42 x 44 x 75cm, low 42 x 44 x 65cm

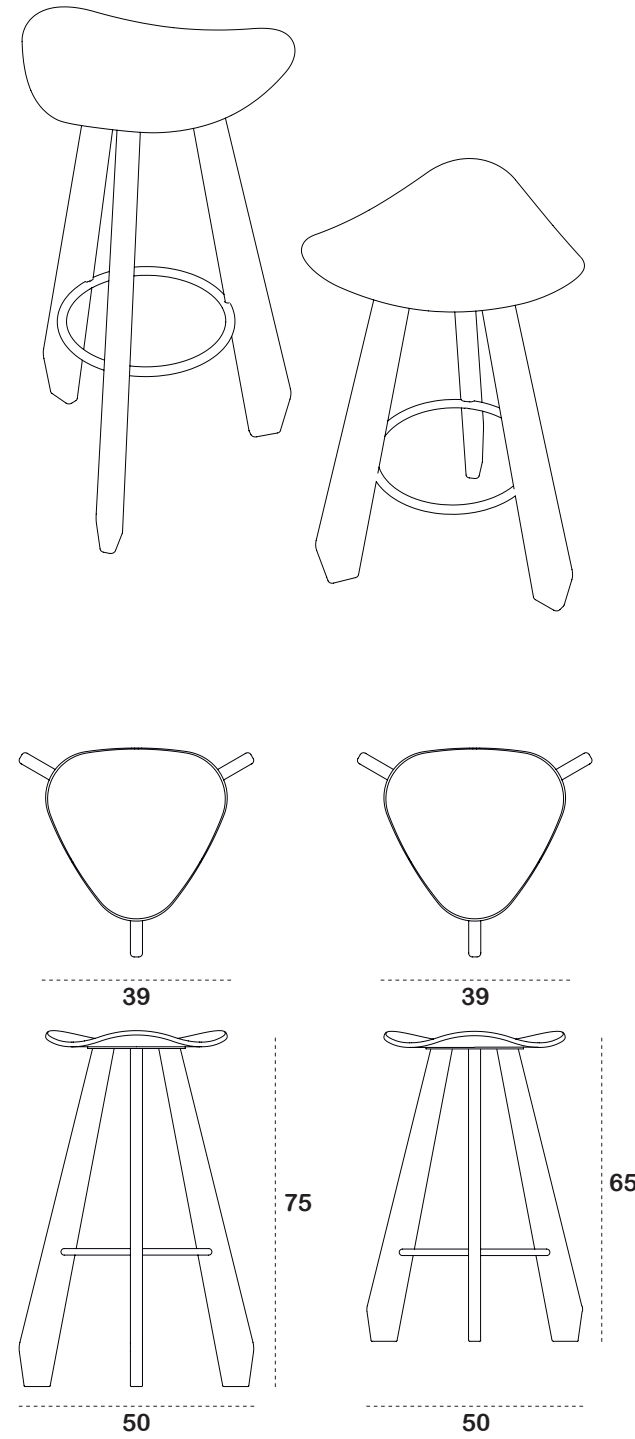

**Description** In its true manner of exploring peripheral typologies, Dante-Goods and Bads presents you its first bar stool: A subtly saddle-shaped plywood seat rests on three solid wood legs, completed with a polished metal ring. Available in standard two sizes, 75 and 65cm.

<b>Material</b>	<b>Brass</b>	
<b>Colours</b>	19.1	<b>satinated brass</b>
		
	19.2	<b>burnished brass</b>
		

**Cleaning advice**







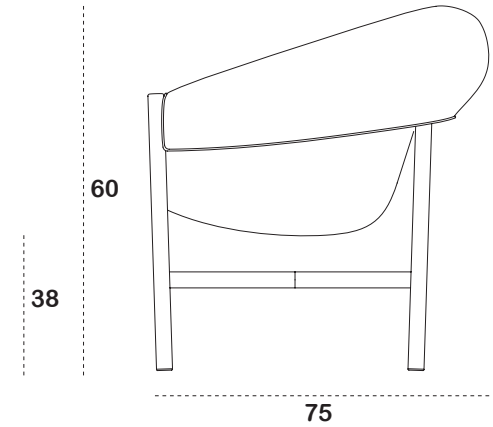
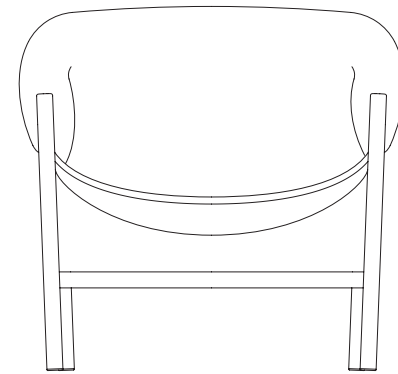
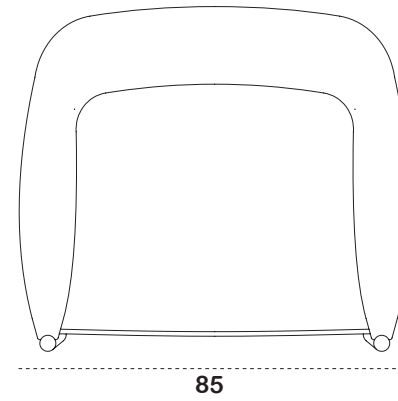
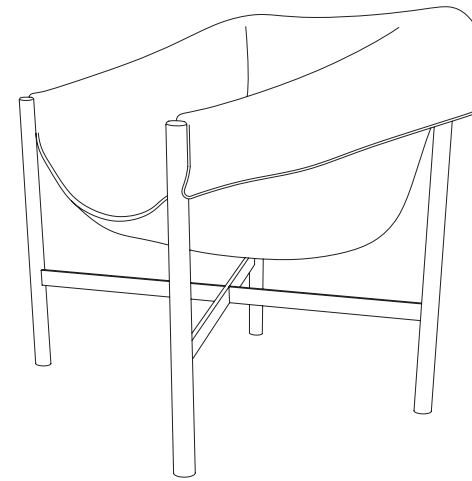

**Brass** To clean the burnishes or polished brass parts of your noble bar stool, all you need to start is a mild dish soap and a warm water rinse. Use a soft, damp cloth to wipe away the soapy water and all the debris, dust, and dirt.

Name	Falstaff
Typology	Armchair
Designer	Stefan Diez

Dimensions 75 x 85 x 38/60cm



**Description** A leather dressed armchair with metal structure. The unconventional way the seat is fixed to the tubular frame is carefully studied in all details. The chair is a result of letting the eye wonder outside the limits of upholstery, resulting in an opulent seat.

Material	Vegan leather		
Colours	05.1	white	
	05.2	grey	
	05.3	rose	
	05.4	curry	
	05.5	forest	
	05.6	sage	



**Vegan leather** To maintain the luxurious appearance of the vegan leather armchair, we recommend regular dusting with a soft microfiber duster to prevent the buildup of dirt and debris. Additionally, periodic application of specialized vegan leather conditioner is essential to keep the material supple and prevent any signs of cracking.



Name	Bavaresk Table Oval
Typology	Dining table
Designer	Christophe de la Fontaine

Dimensions 210 x 105cm, 280 x 110cm

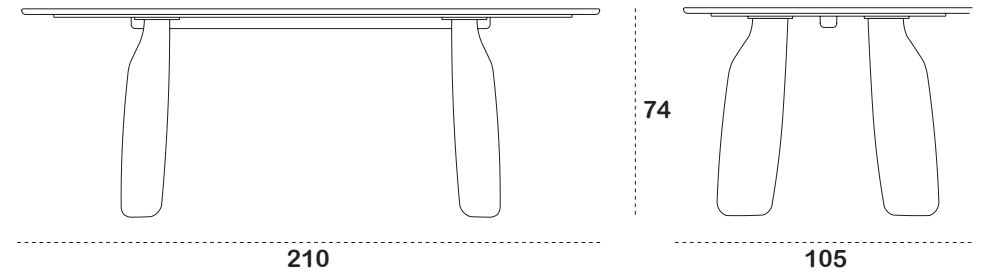
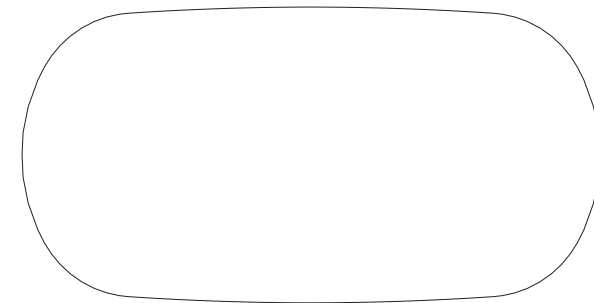
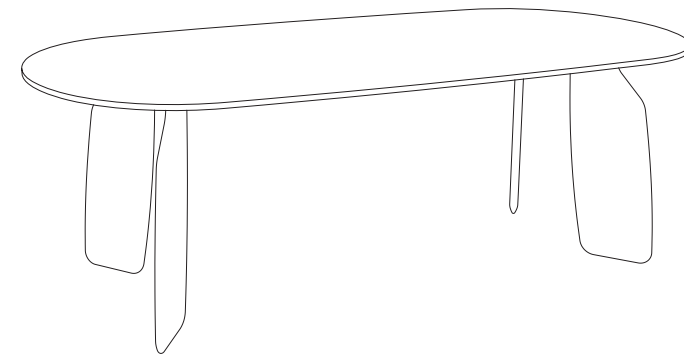

**Description** A dining table with glass, marble or laminate top and beech legs. The iconographic helm-shaped legs are milled out of multiply wood then lacquered or dressed with fabric or leather.

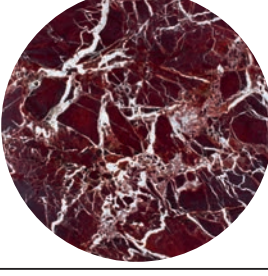
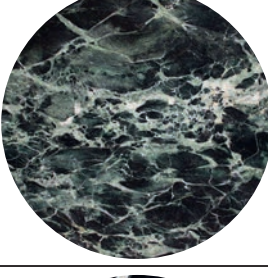
Material	Marble		
Colours	12.1	carrara	
	12.2	silverwave	
	12.3	dedalus	
	12.4	rosso levanto	
	12.5	verde alpi	
	12.6	grand antique	
	12.7	nero marquina	

## Cleaning advice



### Marble

Please be aware that the marble top of your Bavaresk table is a porous material therefore stains penetrate quickly and must be removed immediately; they are particularly sensitive to oils, acids, such as lemon or vinegar, tea and coffee. In case of fingerprints on matt honed surface, please clean with lukewarm water and dry well. Do not use: Metal scrubs, sponges or abrasive products, acidic cleaners.





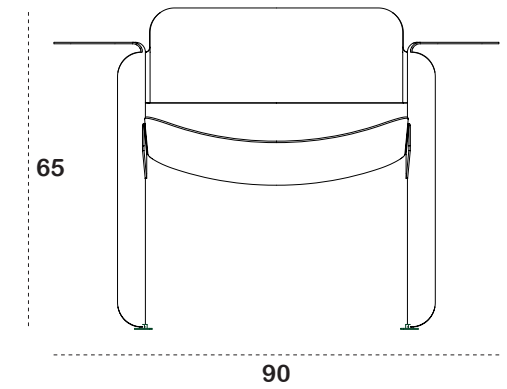
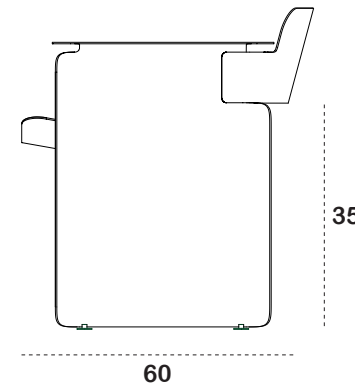
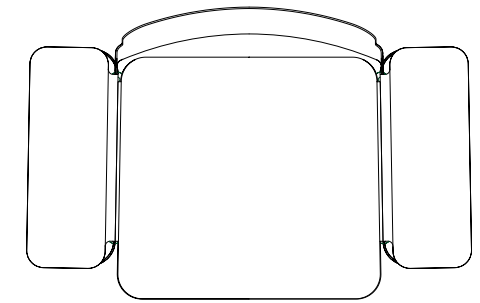
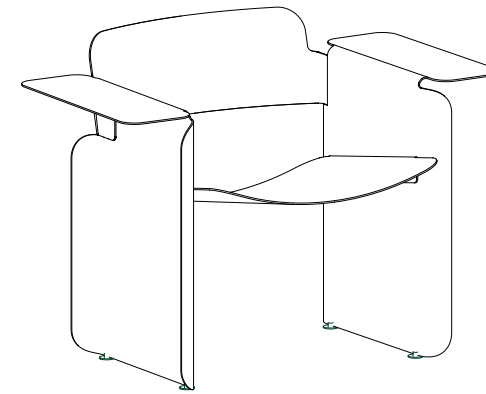

Name	AL13
Typology	Armchair
Designer	Haus Otto

Dimensions 900 x 600 x 680cm

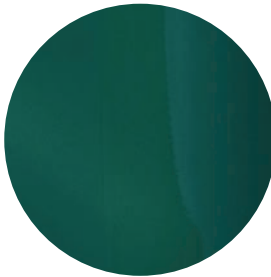
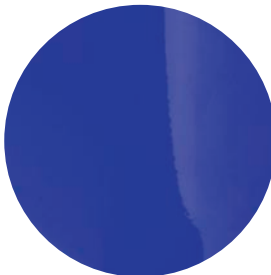

**Description** AL13 is a lounge chair made from laser-cut and bent aluminum sheets. The chair can be used both indoors and outdoors and fits into different spatial environments without losing its very own typology. The highlighted armrest allows for flexible use and can serve as a side table or temporary work space that meets today's needs.

Material	Powder-coated, glossy aluminum or metal	
Colours	17.1	rose
		
	17.2	mint
		
	17.3	framboise
		
	17.4	bluegreen
		
	17.5	electric blue
		



Powder-coated, glossy aluminum

To maintain the chair's pristine appearance, gently remove dust and fingerprints using a feather duster or a dry cloth. For more thorough cleaning, a common window cleaning agent can be applied, followed by thorough rinsing and drying.



Name	Rayons
Typology	Side table
Designer	Christophe de la Fontaine



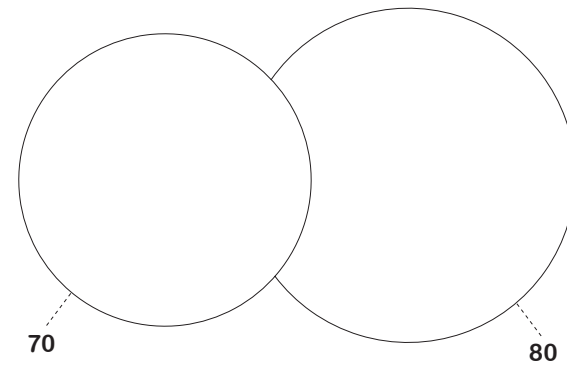
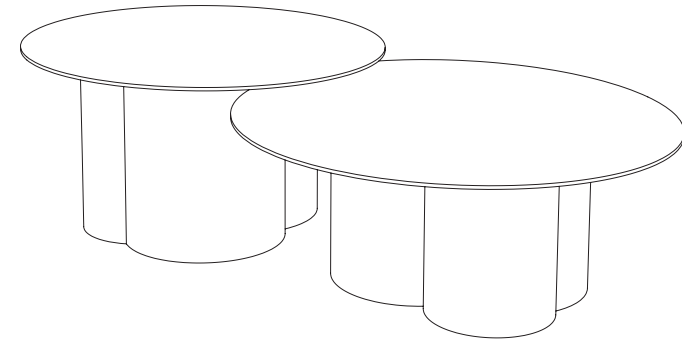

Dimensions high 80 x 34cm, low 70 x 38cm

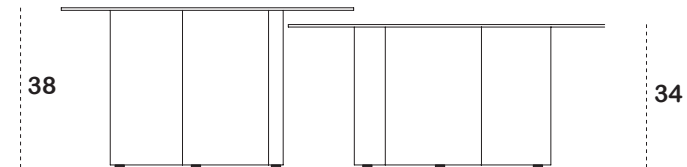

130



**Description** Rayons are a pair of low tables with different heights. The three overlapping radiuses of the base are set out to appear different from every perspective. Rayons explore the minimal variance needed to make a difference – those subtle changes which distinguish an individual from a series, here expressed in the supporting base.

Material	Powder-coated, textured steel or aluminum	
Colours	16.1	white
		
	16.2	champagne metallic
		
	16.4	bordeaux
		
	16.5	bluegreen
		
	16.6	black
		



**Powder-coated, textured aluminum** For regular cleaning, use a soft cloth to keep Rayons in top condition. For a more thorough clean, dilute neutral soap in water and moisten the cloth used for cleaning, ensuring to dry well with a soft cloth afterward. Avoid spraying cleaning products directly on the surface; instead, spray onto the cloth before use to maintain the exquisite look of these tables.



Name	Babel
Typology	Bookshelf
Designer	Christophe de la Fontaine

Dimensions d 40 - 60cm, h 177cm

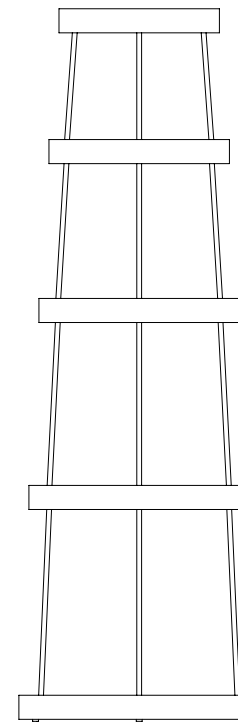
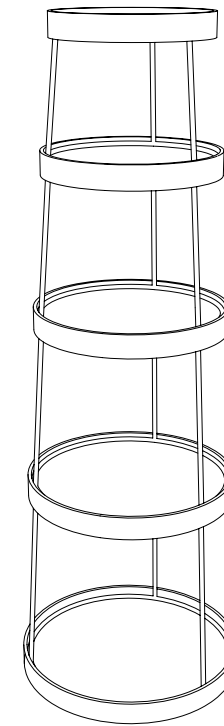

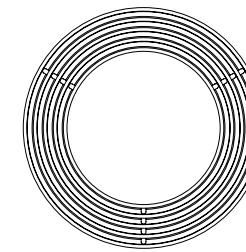

177

60



Description Babel is a bookshelf/etagere composed out of five wooden trays divided by subtle metal structures. Every shelf is fully rotating in order to provide optimal interaction with its content. The tower units can also be separated and used as side tables.



Material	Stained wood	
Colours	14.1	natural
		
	14.2	framboise
		
	14.3	black
		





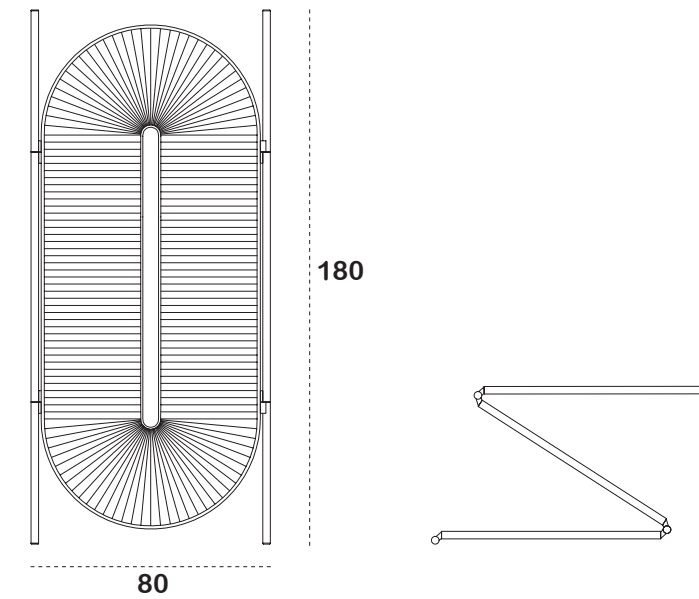
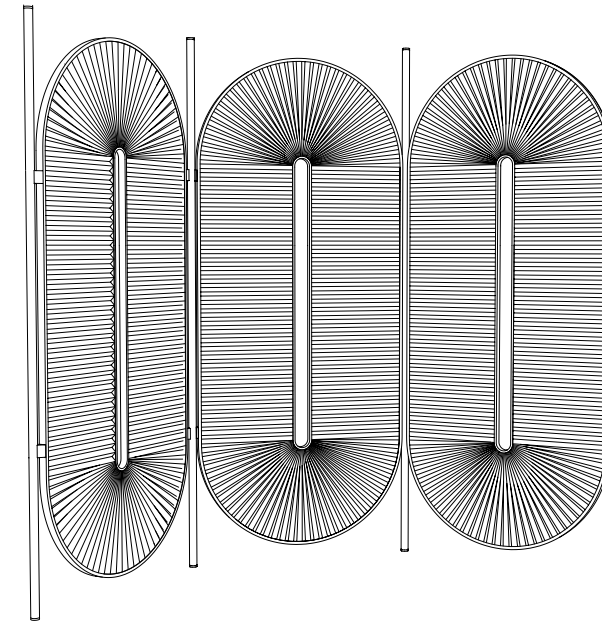
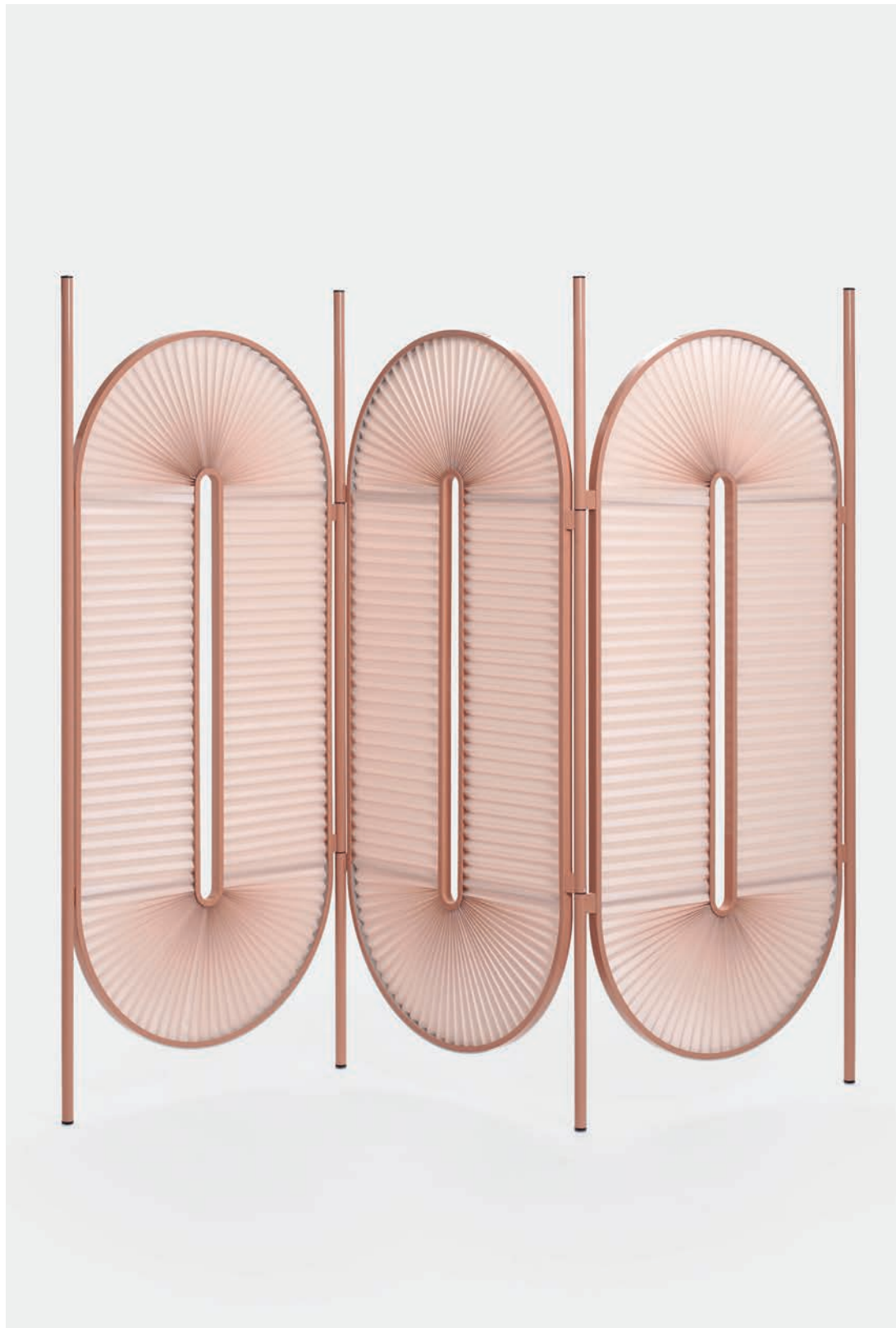

**Stained wood** Tung oil, linseed oil, and Danish oil are all examples of oils that can be used to protect a stained wood surface such as they Babel trays. These oils penetrate deeply into the wood, enhancing its natural color and providing a durable protection.

Name	Minima Moralia
Typology	Room divider
Designer	Christophe de la Fontaine

Dimensions module 80 x 180cm

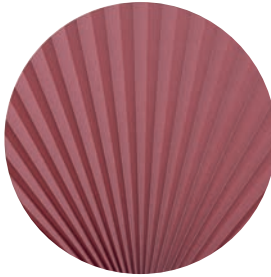

**Description** A room divider with a frame out of powder coated aluminum and pleated fabric. The extremely light-weight modular elements can be positioned both in a C shape and various zig-zag figures. The curves of the construction and a rhythmic vibe to the fabric produce a distinct shadow, resulting in sturdy appearance.

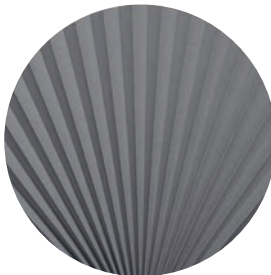
Material	Plissée	
Colours	13.1	white
		
	13.2	rose metallic
		
	13.3	bordeaux
		
	13.4	champagne metallic
		
	13.5	mint metallic
		
	13.6	grey
		



**Plissée** To maintain the pristine beauty of the pleated fabric, we recommend using a soft brush to regularly remove dust and dirt from the pleats. Be gentle while cleaning to avoid damaging the delicate material. For spot cleaning, only use damp cloths and avoid soaking the entire material. By following these simple cleaning tips, you can enjoy the elegance and functionality of our room divider for years to come.



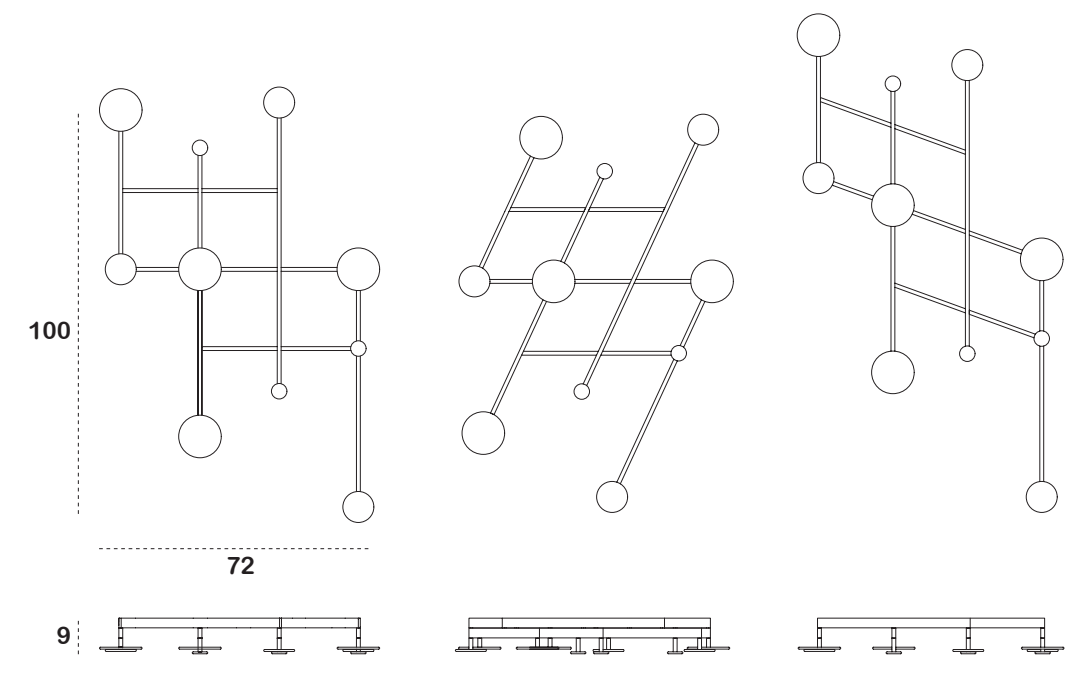
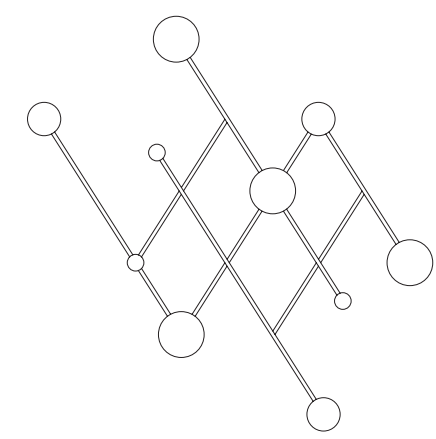
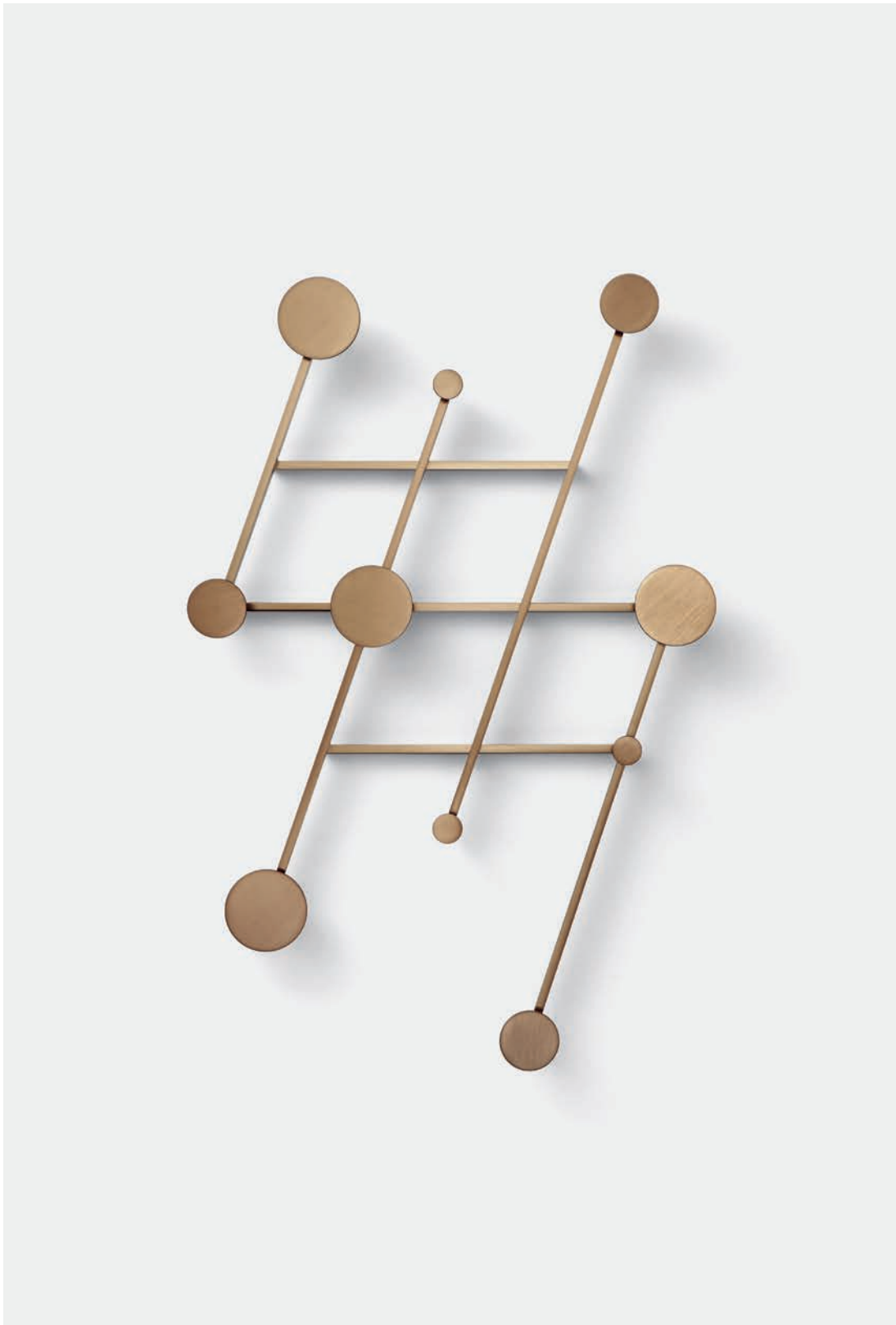

Name	Memoir
Typology	Coat rack
Designer	Jakub Zak

Dimensions 100 x 72 x 9cm



**Description** An aluminum adjustable coat rack. Inspired by the classic accordion style coat racks. Its strong geometries and black and bronze color palette make for a wall piece that is both decorative and functional. The asymmetrical design adds a playful touch.

Material	Anodized aluminium	
Colours	18.1	metal silver
		
	18.2	metal gold
		
	18.3	metal bronze
		



**Anodized aluminium**

To keep the coat rack in perfect condition, use a soft cloth moistened with lukewarm water. In the case of stubborn stains, a cloth dampened with turpentine or a nitro-ecological thinner or degreasing agent can be used, followed by drying with a clean, soft, and dry cloth.

Name	Wonderland
Typology	Mirror
Designer	Christophe de la Fontaine

Dimensions 120 x 20 x 60cm

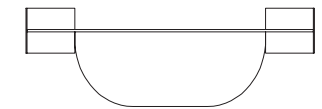
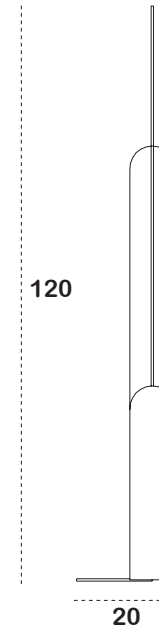
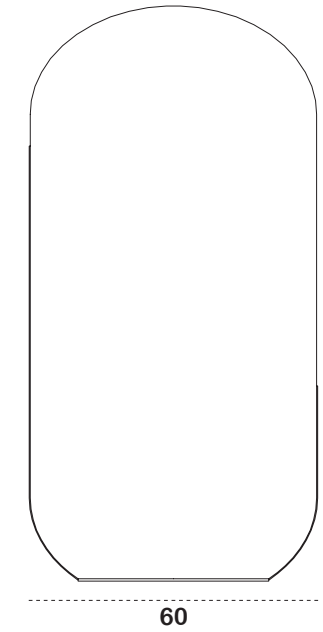

**Description** A wall mirror with a tray. The shape of the plateau is doubled by the mirroring surface, making an illusion of a deeper width which vanishes on the outside. The hidden mounting system is creating an Aliceinwonderlandesque floating effect.

Material

Mirror

Colours

ø9.5

tan

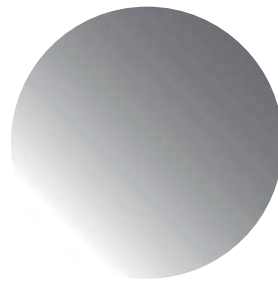

Cleaning advice



Mirror

To clean mirrors with stubborn stains, begin by removing any tough stains caused by hairspray or makeup with a little rubbing alcohol on a soft cloth. Next, use your preferred cleaning solution or glass cleaner to spray the mirror. Then, wipe the mirror with a microfiber cloth in straight lines, working from edge to edge and top to bottom, avoiding circular motions.





Name	Bavaresk High Chair
Typology	Dining chair
Designer	Christophe de la Fontaine

Dimensions 50 x 48 x h 45/94cm

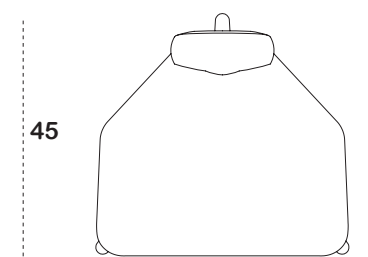
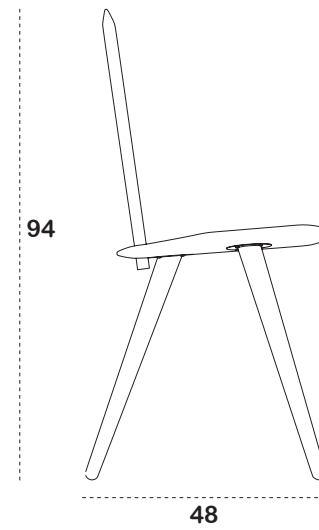
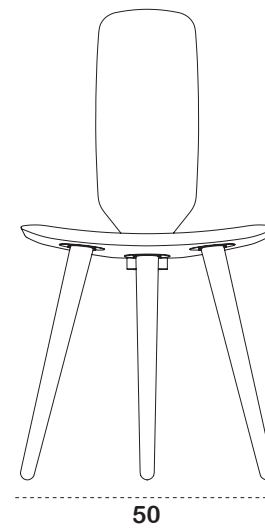
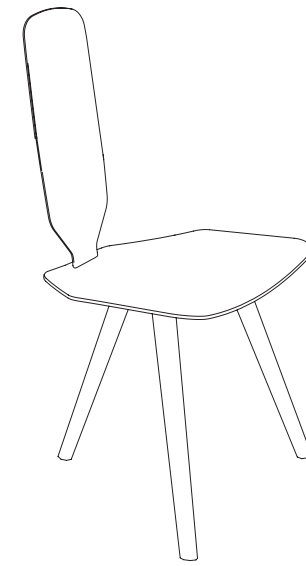

**Description** A three-legged dining chair made out of beech. The joint of a classical rural Bavarian wooden chair was revised by eliminating the plank solution with CNC processing; legs are reduced from typical four to three. The mood of the smooth lines competes with an obi sash-like cushion.

Material	Vegan fur curly	
Colours	10.1	white
		
	10.2	creme
		
	10.3	rose
		
	10.4	grey
		
	10.5	bluegreen
		



**Vegan fur curly** To care for your Bavaresk dining chair made of vegan fur curly, gently shake and brush the vegan fur regularly to remove loose dirt and debris. Use a soft-bristled brush to restore its fluffiness and maintain its texture.

Name	Come As You Are
Typology	Bar cart
Designer	Christophe de la Fontaine

Dimensions 80 x 40 x 80cm

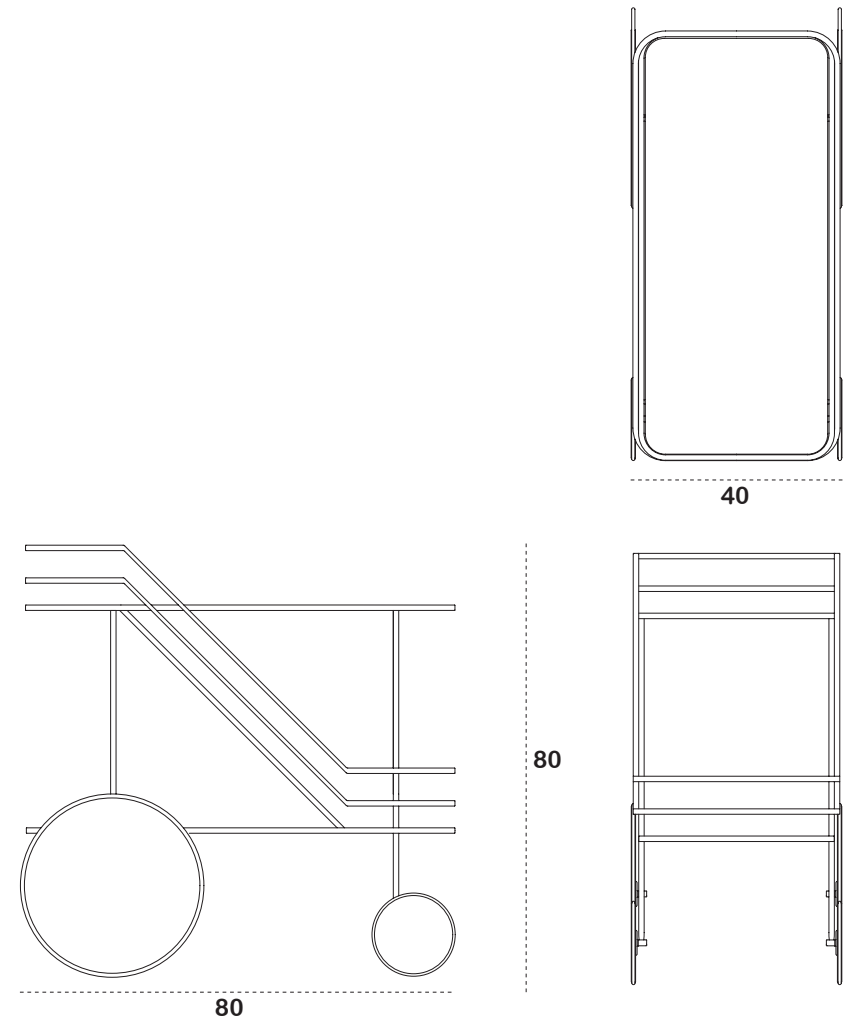

Description	The graphical and bi-dimensional bar cart references the classic hostess service trolley. Pared down to its bare essentials, the piece comes in steel and features two horizontal surfaces for increased capacity.
-------------	--

Material	Glass
Colours	ø8.1 fume



Cleaning advice

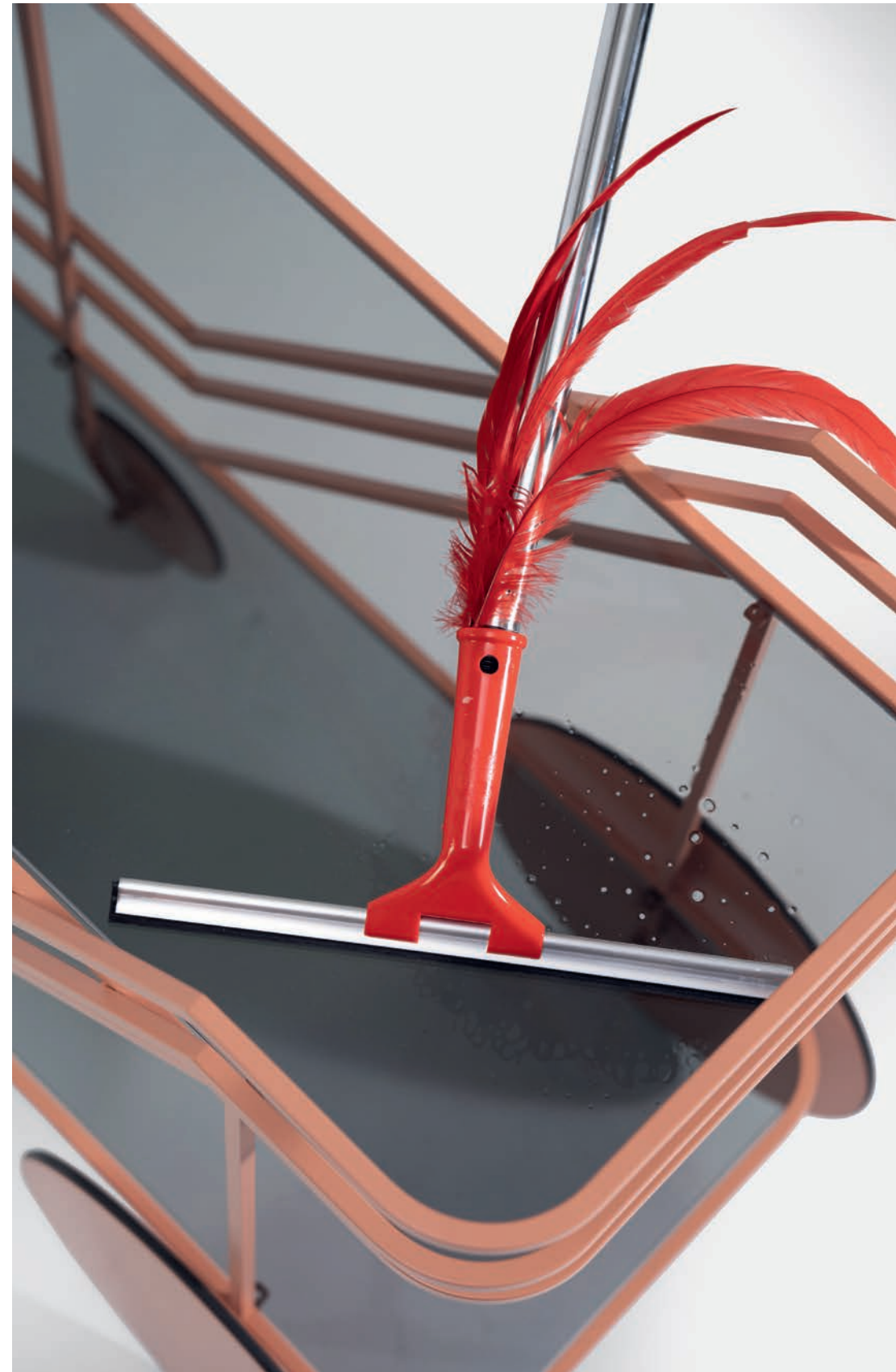

**Glass** To clean the glass surfaces of our most famous product “Come As You Are”, use soap and water or any commercial glass cleaner while avoiding direct sunlight to prevent streaking.



Name	Biscotto
Typology	Bench
Designer	Christophe de la Fontaine

Dimensions 128 x 48 x 44cm

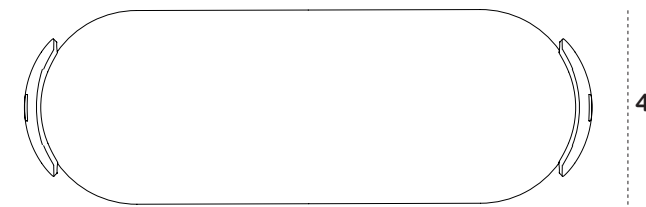
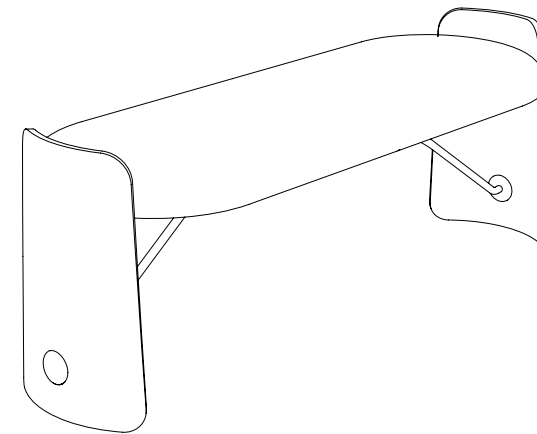

44

128

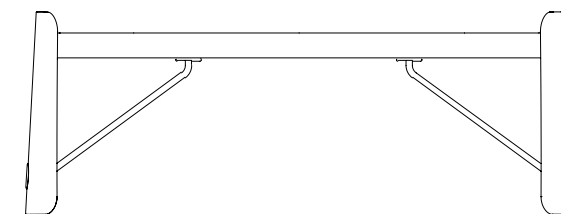

48

43

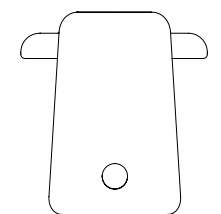

**Description** Biscotto is a wooden bench with a leather upholstered seat and brass truss connections. Following Dante-Goods and Bads's tradition of serving satellite typologies, the bench becomes a multitool that can't be reduced to its mere function as a temporary seating solution. The essence of Biscotto lies in the dialogue between the gently curved plywood legs and the firm mattress, confronting one another while leaving the constructive elements exposed. Biscotto's substantiality makes it a perfect fit for both entrances and living, as well as personal spaces in the moments of hushed comfort.

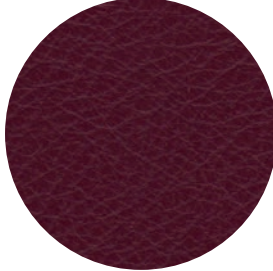
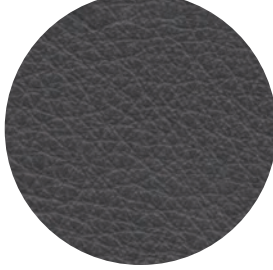
Material	Leather thema	
Colours	09.5	tan
		
	09.7	bordeaux
		
	09.9	grey
		

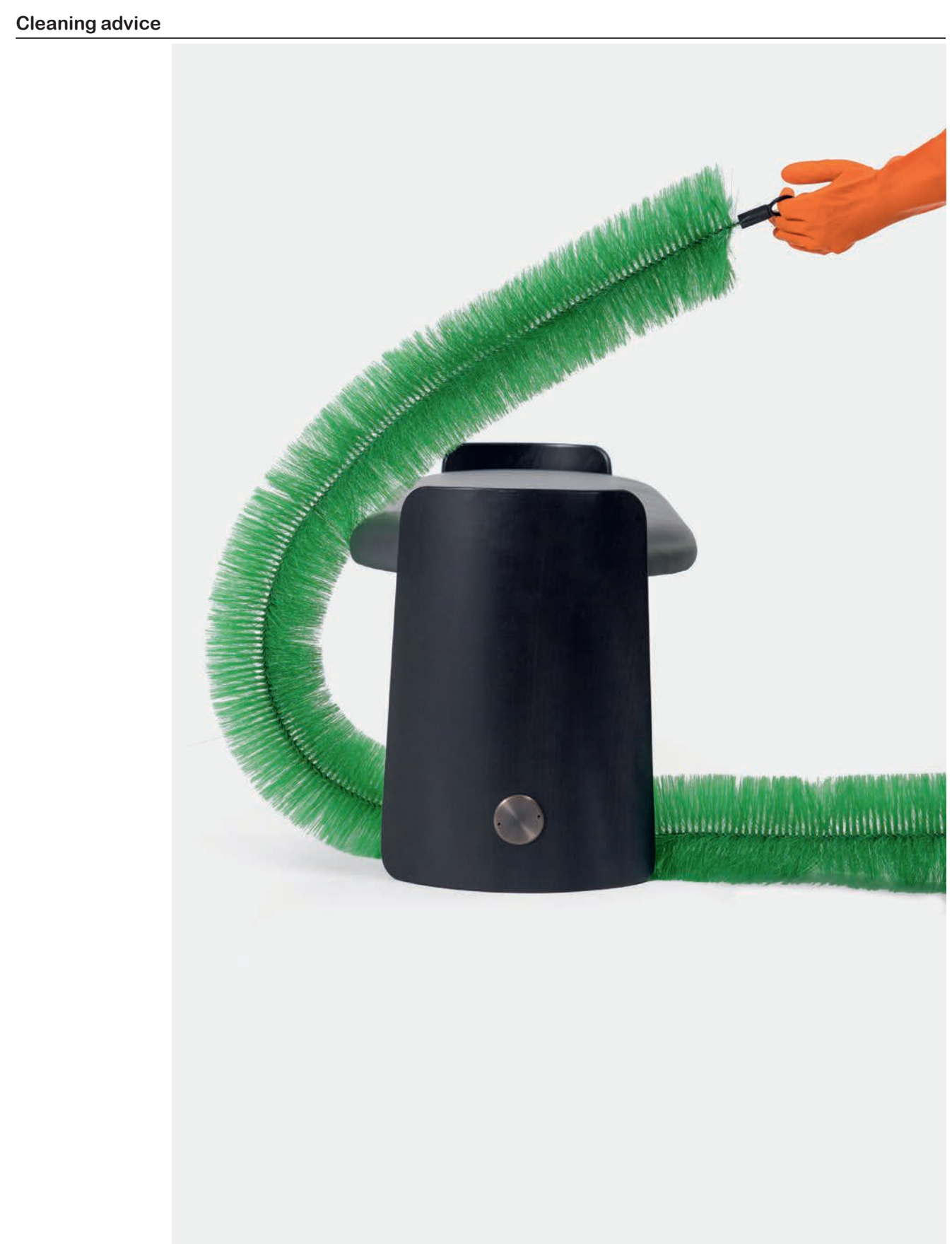

**Leather thema** To prevent genuine leather from drying out and becoming brittle, it should be treated once or twice a year with a commercially available leather care oil, cream or leather grease. Regarding the gloss level of the product, it should be mentioned that leather grease promotes the shine of a leather the most.



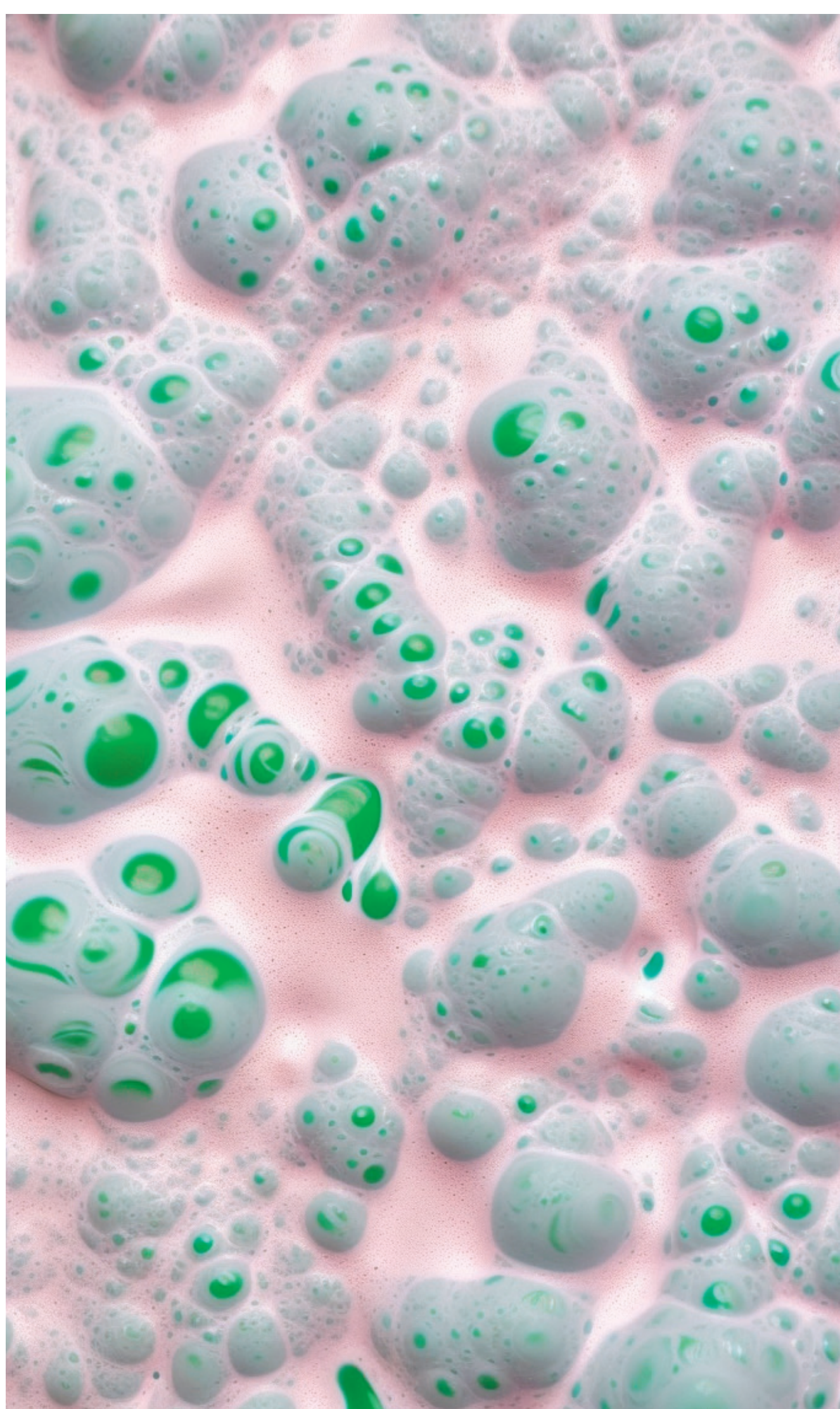

Name	El Santo
Typology	Armchair
Designer	Christophe de la Fontaine

Dimensions 80 x 67 x 80cm

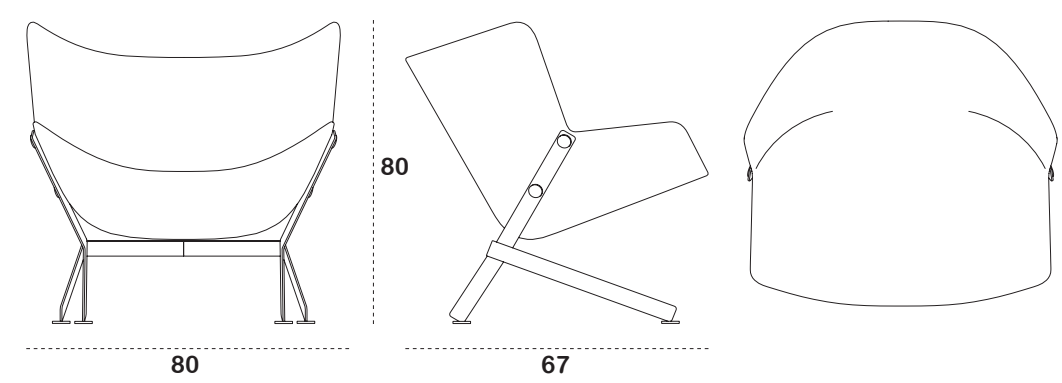
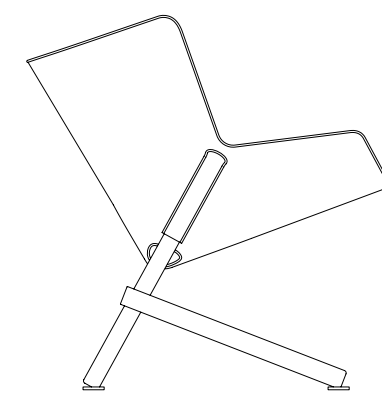

Description	A simple seat folded into shape using a flat piece of sturdy leather. The resulting shell, when fixed to its unusual metal base, appears left floating in the air. This unexpected take on the classic cantilever typology results in a spacious, comfortable seat.
-------------	---

Material	Vegan fur teddy	
Colours	11.1	white
		
	11.2	grey
		
	11.3	rose
		
	11.4	curry
		
	11.5	bordeaux
		
	11.6	moss green
		
	11.7	electric blue
		



**Vegan fur teddy** In general you can use a vacuum cleaner with a soft brush attachment to remove dust and dirt from the armchair. If the El Santo fluffy armchair needs a thorough cleaning, it is best to wash it by hand. Fill a bowl with lukewarm water and add a small amount of mild detergent. Dip a soft cloth or sponge into the soapy water and gently clean the surface of the vegan coat. Rinse with clean water to remove all soap residue.

Name	Charlotte
Typology	Chaise longue
Designer	Christophe de la Fontaine

Dimensions 145 x 50 x 90cm

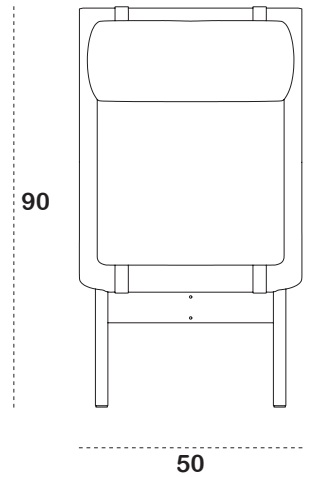
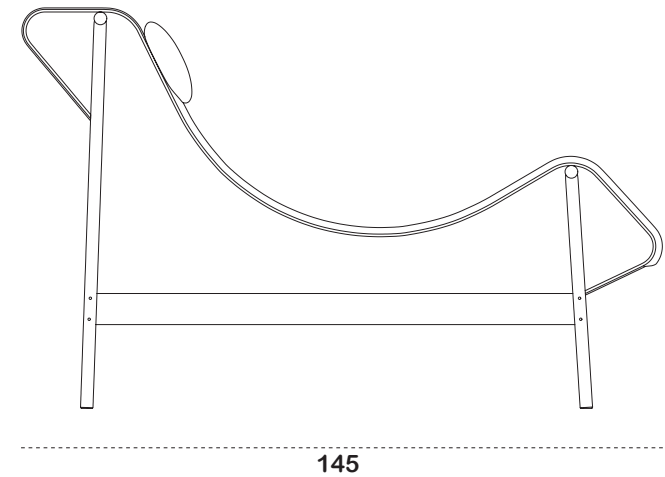
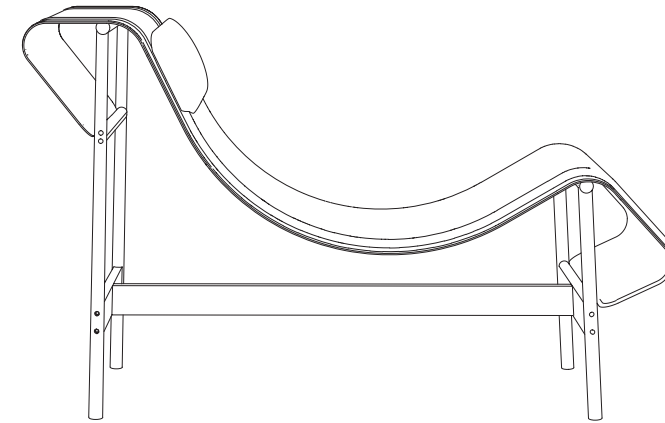

**Description** Charlotte is an aluminum chaise longue with a removable leather mattress and adjustable headrest. It's an extremely compact reinterpretation of a well-known classic, available in both polished and powder-coated finish, as well as various colors of leather. The construction-free mattress, even though giving an impression of a sturdy curve, has a free flow, adjusting its form to the body's natural shape.

Material	Split leather	
Colours	07.1	white
		
	07.2	tan
		
	07.3	dark brown
		
	07.4	bordeaux
		
	07.5	dark grey
		
	07.6	black
		



**Split leather** Please wipe the split leather furniture regularly with a damp cloth, working from top to bottom. Allow it to air dry and then polish it with a cloth moistened with leather cleaner.





Imprint

Art direction by Aylin Langreuter  
Words by Lea Schmidbauer  
Graphic support by Jana Rzehak  
Photography by Katarina Circovic  
Always the best Martina Kojic





